

# CAKJ-XXS-288E Central Signal Alarm System

## 1 Overview

CAKJ-XXS-288E Central Signal Alarm System, a centralized management microcomputer signal alarm system designed specifically for the signal system of power plants and substations. It has the characteristics of strong anti-interference ability, simple operation, convenient installation and use, and low maintenance. This alarm system adopts a distributed structure. The "alarm host" collects alarm data from the "open-in module" through the field bus, and transmits the obtained alarm signal to the alarm "alarm window box" and "alarm sound" according to the internal setting instructions of the host, completing the sound and light alarm of the fault signal. This product is widely used in power, petroleum, chemical, metallurgical, and coal industries, and is a highly intelligent product for power and industrial automatic monitoring and signal alarm.

Light Word Plate Box Host Open-in Module Drive Module

2, Model Number

CAKJ-XXS-288E Central Signal Alarm System

(including the following components)

CAKJ-XXS-MZQ Central Signal Alarm Device(Host)	1 set
CAK J-32DIT 32-channel signal open-in module	9 set;
CAKJ-XXS-64GP 64-channel light word plate box	4 sets
CAKJ-XXS-32GP 32-channel light word plate box	1 set
CAKJ-MZQ-RJ45 Light Word Plate Drive Module	1 set
CAKJ-KDY-24 Switching Power Supply	2 pieces
CAKJ-DL Electronic Bell	1 piece
CAKJ-DD Electronic Whistle	1 piece
LA38-11φ22 Function Button	
(Red Blue Yellow Green White) each 1 piece	



## 3. Functional Features

1. The alarm host panel is equipped with a liquid crystal display: displays the operating clock, open-in module abnormality, signal alarm records, etc., and has the function of self-checking after power-on.
2. Function Button: It has the functions of test (test light), confirmation (accept, mute, reset, recall, etc.) external function button terminal.
3. Fault recording function: Record the time of occurrence of alarm signal fault (year, month, day, hour, minute, second), record the time of alarm signal fault removal (year, month, day, hour, minute, second).
4. It has the function of manual and automatic confirmation, and the automatic confirmation time (0-20 0s) can be set.
5. Signal delay alarm: 0-9999ms delay alarm time can be set.
6. Signal alarm type can be distinguished: can be set to distinguish between accident signal F, warning signal W, position signal L.
7. Light word plate color: You can choose red, yellow-green, and distinguish more clearly and intuitively by color according to the alarm type of the signal.
8. Input signal type can be set: switch type contact (K), switch type hold contact (E), and pulse type hold contact (P). (Note)
9. Input signal normally open normally closed selection: For each signal, normally open change normally closed alarm (O default) can be set, normally closed change normally open alarm (C) can be set.
10. You can arbitrarily mask or start the input signal alarm.
11. The device is equipped with a buzzer, and the accident sends a long sound "Di---", the warning signal sends a short sound "Di, Di, Di, Di", and the position signal does not sound.
12. The device is equipped with accident and warning signal alarm output contacts, which can start the electric whistle and bell, and strengthen the sound alarm effect.
13. It has a device power disappearance contact output.
14. It has digital communication output, RS485 serial communication interface, MODBUS communication protocol.

Note: Switch type contact K: the normally-open contact, when the system malfunctioning, the contact will close, the device alarms, when the fault is clear, the contact will disconnect, the alarm will be reset.

Switch type maintain contact E: when the system malfunctioning, the contact will close, the device alarms, when the fault is clear, the contact will be disconnected, the alarm signal will be maintained hold, require manual reset.

Pulse-type hold contact P: Pulse-type normally closed contact, which will close for 1s and then open while the system malfunction occurs, and the alarm remains when the fault removed, require manual reset.

## 4. General Technical Requirements

1. Working Power Supply: DC220V, DC110V, DC125V, AC220V, AC240V (optional).
2. Signal Capacity: 256 circuits (8 pieces of 32-circuit opening modules).
3. Input Signal Mode: Normally open or normally closed passive dry contact.
4. Alarm window: Illuminated window size 30x30, color: red, yellow, green, white (optional).
5. Alarm Output: Alarm window flashing, buzzer or audio sound.
6. Alarm Sound: Buzzer beep 60dB; amplified audio able to choose CAKJ-DL bell, CAKJ-DD whistle as optional.
7. Contact Output: 3 relay contacts output, corresponding to power failure, warning alarm, and accident alarm respectively.
8. Contact Capacity: AC250V, 3A pure resistive load, DC220V, 0.125A inductive load.
9. Function Settings: click set button, LCD display.
10. Power Consumption: less than 50W for the whole set.
11. Communication Interface: Standard RS485 serial communication interface, MODBUS communication protocol.

- 12. Insulation resistance: No less than 100MΩ between input-output-power supply-case .
- 13. Rated Voltage Withstand Capacity: The input-output-power supply-case can withstand a test of 2 kv, 1min, 5mA, 50/60Hz without any flashover or breakdown.
- 14. Anti-interference Capacity: The product can withstand the high-frequency interference test of 1MHz and 100kHz attenuated shock waves. The voltage amplitude of the first half-wave is 2.5kV common mode and 1.0Kv differential mode. The product should not exhibit any misoperation or refusal operation phenomenon.
- 15. Environmental Conditions: Ambient temperature range between -10°C~60°C; ambient humidity not above 90%.
- 16. Weight: 5kg

## 5. Apparatus Set-up and Record Viewing

1. Instrument setting: There are 5 setting keys on the instrument panel, "SET" to set and confirm, "←" to move cursor left (left), "→" to move cursor right (right), "RETURN" to return to the previous menu when the cursor is not flashing, "↑" to add 1 (up), "↓" to subtract 1 (down), and "EXIT" (setting exit key, return to the running interface).

Press SET button into setting	Main menu	Move cursor to setting for detail setting, beware with clear records.				
Password Please enter passwords: 0000 Then press SET button	System setting →clock calibration Signal setting Communication setting	Clock calibration System time calibration Please enter date, time yyyy/mm/dd hr.min.sec	Clear records Clear records Please confirm No or Yes Then press SET button	Black light time LCD black light time selection Please select 10s, 30s, normally on Then press SET button		
Note: default password 8080	Clear records Backlight time Return Note: main menu need to turn the page to display.	Communication setting	Entering address, baud rate and verification methods selection.			
		Device address Baud rate Verification methods Return	Device address Please enter 001-255 Then press SET button	Device baud rate Please enter 9600 or 4800 Then press SET button	Verification methods Please enter Null, odd, even Then press SET button	
Signal setting	Signal total number enable to set, confirm time and delay needs entering, audio setting by selection.					
→total signal no. Auto confirm Delay setting Detailed setting	Total signal number Total signal number Please enter N route Then press SET button	Auto confirm Auto confirm time Please enter 10s, (0-200s) Then press SET button	Delay setting Delay alarm time Please enter 20ms(0-999ms) Then press SET button	Audio setting Audio setting Please select All on, off, buzzer only, electric speaker only Then press SET button		
Audio setting Return						
Detailed setting	The form listed below are the setting method and meaning					
Signal detailed setting Please enter 001route Then press SET button	Signal detailed setting N I S J B →1 K F O R 2 K F O R 3 P L C D · · · · ·	N routes →1 2 3	I enter status K switch contact(instant) E switch contact(maintain) P pulse contact(maintain)	S alarm type F Failure alarm W warning alarm L location alarm	J normally open/close O normally open contact O normally open contact C normally close contact	B on or off R signal on R signal on D signal off
Please enter specify route, press SET button move to the route need setting.	N-1 K W O R N K W O R	Setting method: press up and down to select route, press SET button, while cursor flashing, press Up and Down button select to enter, press Left and Right to move, set I, S, J, B in order. When setting finish, press SET again, cursor not flash, at this condition press Up and Down to select other route, press Right return to previous page, press SET to exit setting.				

### 2, Records View

During normal operation, press the "↑" key or the "↓" key to enter the record review interface, Press "↑" or "↓" to scroll through records 1-200. Press the "←" key to exit record view.

Alarm Record No. 148 July 18, 2015 13:58:25 Signal No. 24 activated	Alarm Record No.149 July 18, 2015 14:01:05 Signal No.24 returned
--	---

### 3. Alarm display

Signal Alarm Record 2022-03-05 14:35:26 Normal Monitoring Interface,	Signal Alarm Record Input module 06 abnormal 2022-03-05 14:35:26 Abnormal Input Module Interface,	Signal Alarm Record 2022-03-05 14:35:26 No.026 signal action Signal Loop Alarm Interface
---	--	--

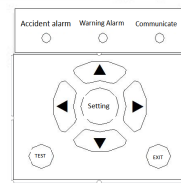

When the accident signal alarming the accident indicator is on.  
when the warning signal alarming the warning indicator is on.  
when the external communication is connected the communication indicator is on.

Note: when the input module is abnormal, please check if the module address is set correctly and uniquely, whether the module power indicator is on, and whether T+ and T- are connected. When the input module is connected to the host, the power indicator is on, and the data transmission indicator of the input module is flashing, then press the "Exit" key on the panel to restore normal.

## 6. Apparatus Alarm and Inspection

1. Power on self-test, connect the device to the power supply, all the alarming windows are on and the LCD display panel shows "The system is self-checking, starting". The alarm windows off after the self -test is completed, and the LCD screen shows the date and clock.
2. Press the "Test" button, all the alarm windows flash, the buzzer sounds, and the audio output contacts act. Press the test button again to return to the monitoring state.
3. When a signal alarm occurs, the corresponding alarm window flashes, the buzzer sounds, the audio output contact acts, and the bell and whistle are sounding. The LCD display window shows the date and time as 20XX-XX-XX XX:XX:XX, signal number 0XX has been activated.
4. Press the "Silence" button, the alarm window continues to flash, the buzzer is silent, the audio output contact returns, and the bell and whistle are silent.

5. Press the "Confirm" button (or automatic confirm after 0-200s), the alarm window will chang from flashing to steady, the buzzer silence, the audio output contact will return, the electric bell and whistle will be silent, and the LCD will display the real-time clock.
6. When the signal is reset, the signal input by the switch contact goes out. The signal input by the holding contact remains in alarm and the signal light goes out only after manual reset (pressing the external "reset" button). The LCD display window shows "20XX year XX month XX day, XX hour XX min ute XX second, signal number 0XX returns".
7. Press and hold the "Recall" button, the signals that have been reported will be displayed on the alarm window in order of their reporting, following the principle of LIFO (Last In, First Out), up to 200 signals can be recalled, with alarm recall taking priority during the recall process.

**7. Appearance and wiring**

1, CAKJ-XXS-MZQ

◆External view Host



◆Dimensions and installation size

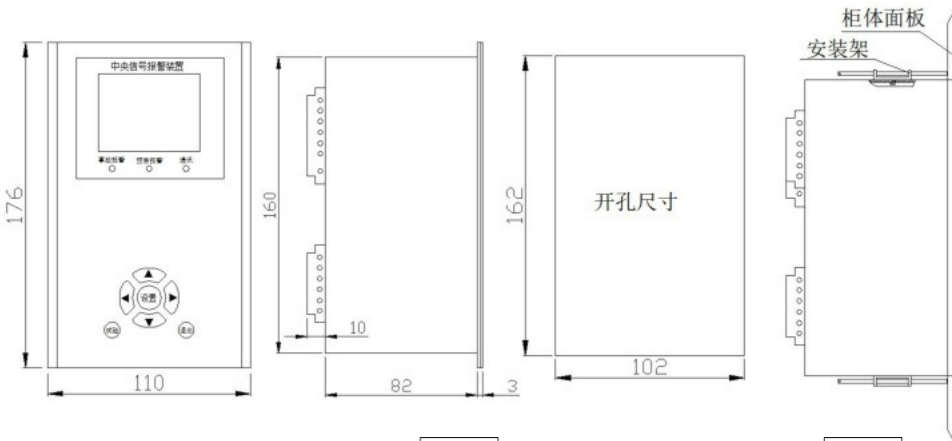

◆ Terminal and position diagram (rear view)

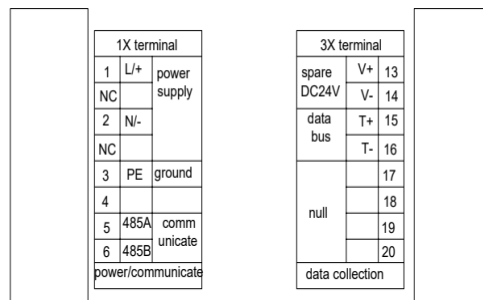

to alarm window case RJ1

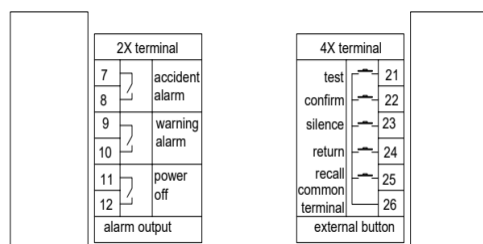

2, CAKJ-32DIT Input Module

◆ External view Input Module



◆ Dimensions and installation size

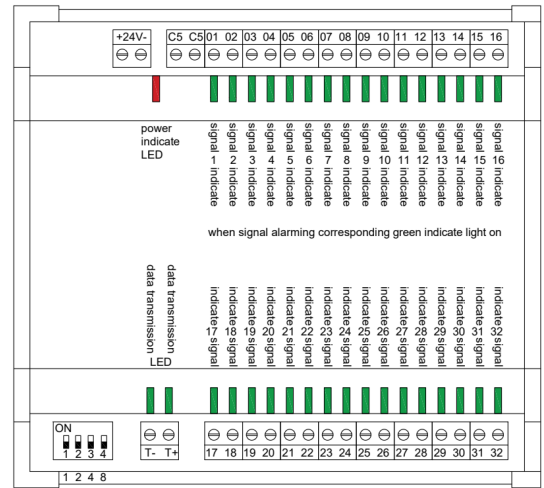
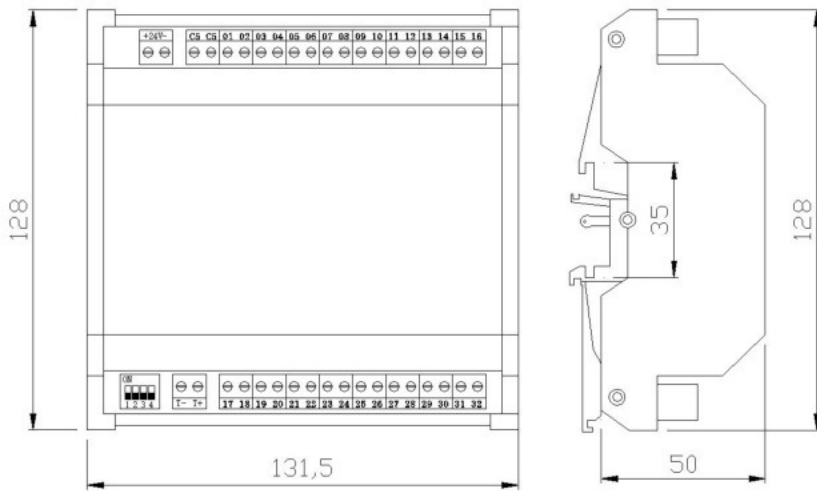

◆ Terminal Connection Diagram and Location Chart

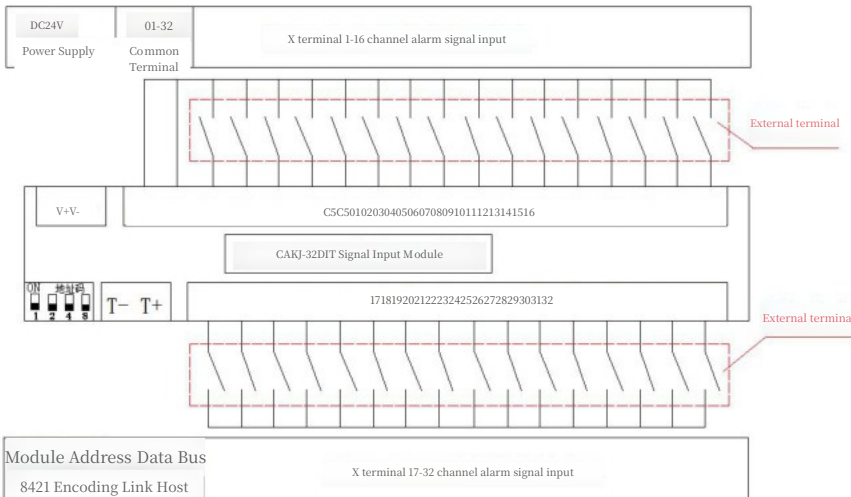

1. Please perform the following checks before connecting the DC24V power supply:
  1. Please check if the address code is set correctly and uniquely. Set the address code as the method shown in the figure below.
  2. Check if the T+ and T- data transmission buses are connected correctly (between modules and between modules and the host, T+ and T- should not be connected reversely).
  3. The input signals have been connected to the modules in order of alarm, referring to the note below to understand the relationship between the address code and the signal.
  4. The host has been powered on and various program settings have been made.
2. Connect the DC24V power supply:
  1. The red LED will light up, the green LED for data transmission will flash.
  2. When a signal alarm occurs, the corresponding green indicator light on the module will light up, such as for signal 01 alarm, the corresponding 01 indicator light will be on.
  3. Do not change the address code after power on. Changing the address code must be done under power-off conditions.
  4. The input signal can be connected or adjusted under power-on conditions.



Note: Module power DC24V (V+, V-), power access is necessary. Data bus (T+, T-), multiple modules are reconnected in parallel, and the alarm data will transfer to the host (T+, T-) end. Each module has a unique address code, please set the address code before the module connected to the host, and the address code is encoded according to the 8421 principle.

Signal Alarm Circuit corresponding to Address Code: number 1 corresponds to 01-32 signal circuits, number 2 corresponds to 33-64 signal circuits, number 3 corresponds to 65-96 signal circuits, number 4 corresponds to 97-128 signal circuits, number 5 corresponds to 129-160 signal circuits, number 6 corresponds to 161-192 signal circuits, number 7 corresponds to 193-224 signal circuits, number 8 corresponds to 225-256 signal circuits. Please ensure that the address code is set correctly before powering on to avoid abnormal errors in the alarm module

### 3, CAKJ-XXS-64GP

#### ◆External View

#### Alarm Window Case



#### ◆Dimensions and installation size

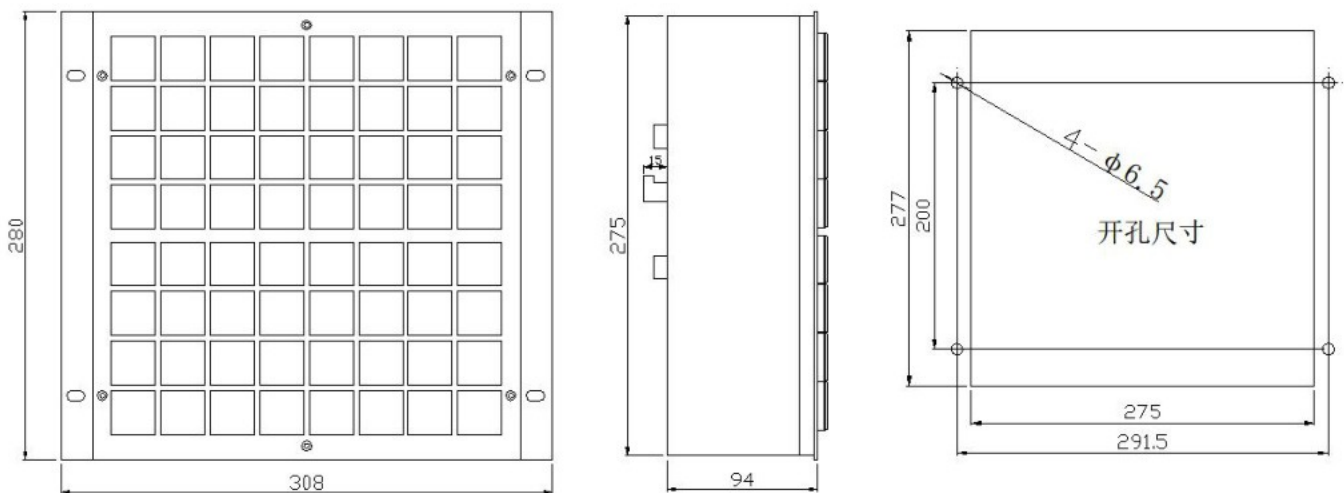

#### ◆Wiring Diagram

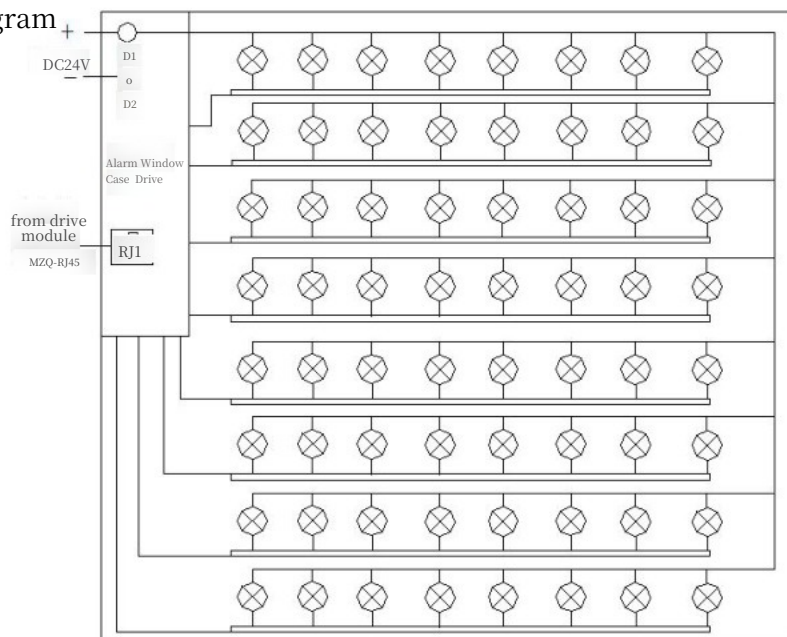

### 4, CAKJ-XXS-32GP

#### ◆External View Alarm Window Case

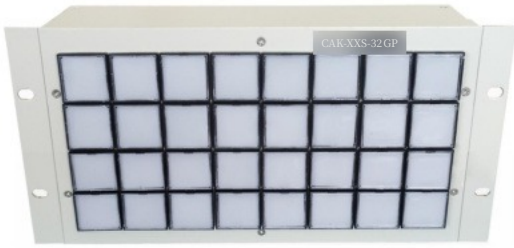

#### ◆Dimensions and installation size

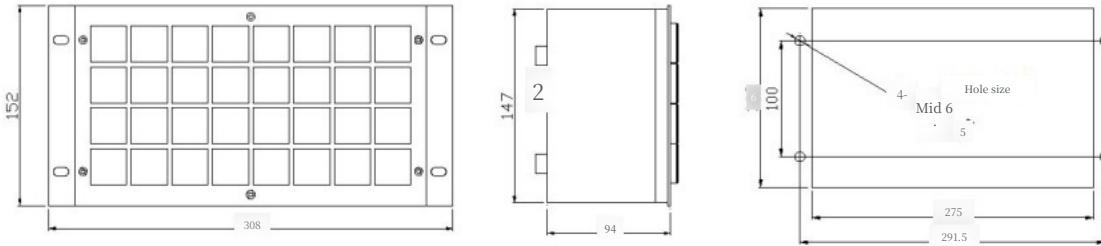

#### ◆Wiring Diagram

CAKJ-XXS-32GP光字牌箱原理接线图

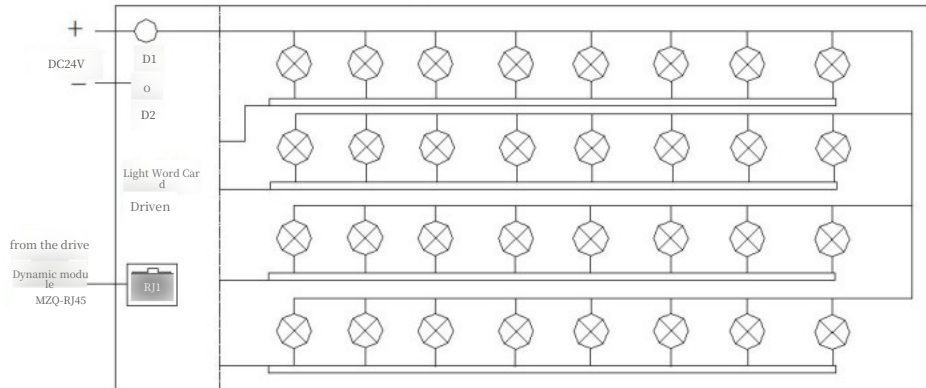

### 5, CAKJ-MZQ-RJ45 Alarm Window Case Drive Module

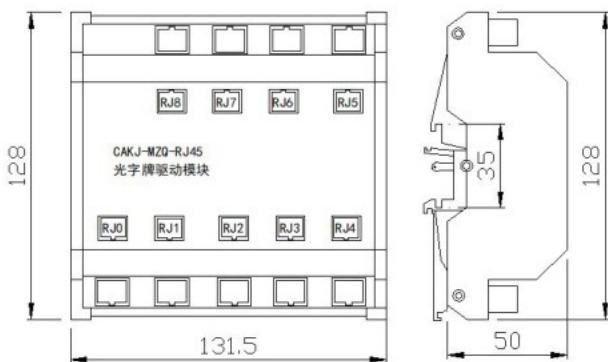

Note: RJ0 is connected to the main unit of the alarm device, RJ1-RJ8 are connected to 1-8 alarm window case separately (according to the number of alarm window case),  
 such as 256 route(64GPx4), configure RJ1-RJ4 with 5 terminals  
 288 route(64GPx4+32GP), configure RJ1-RJ5 with 5 terminals  
 320 route(64GPx5), configure RJ1-RJ5 with 5 terminals  
 384 route(64GPx6), configure RJ1-RJ6 with 6 terminals  
 448 route(64GPx7), configure RJ1-RJ7 with 7 terminals  
 512 route(64GPx8), configure RJ1-RJ7 with 8 terminals

### 6, CAKJ-XXS-288E Alarm System Wiring Diagram

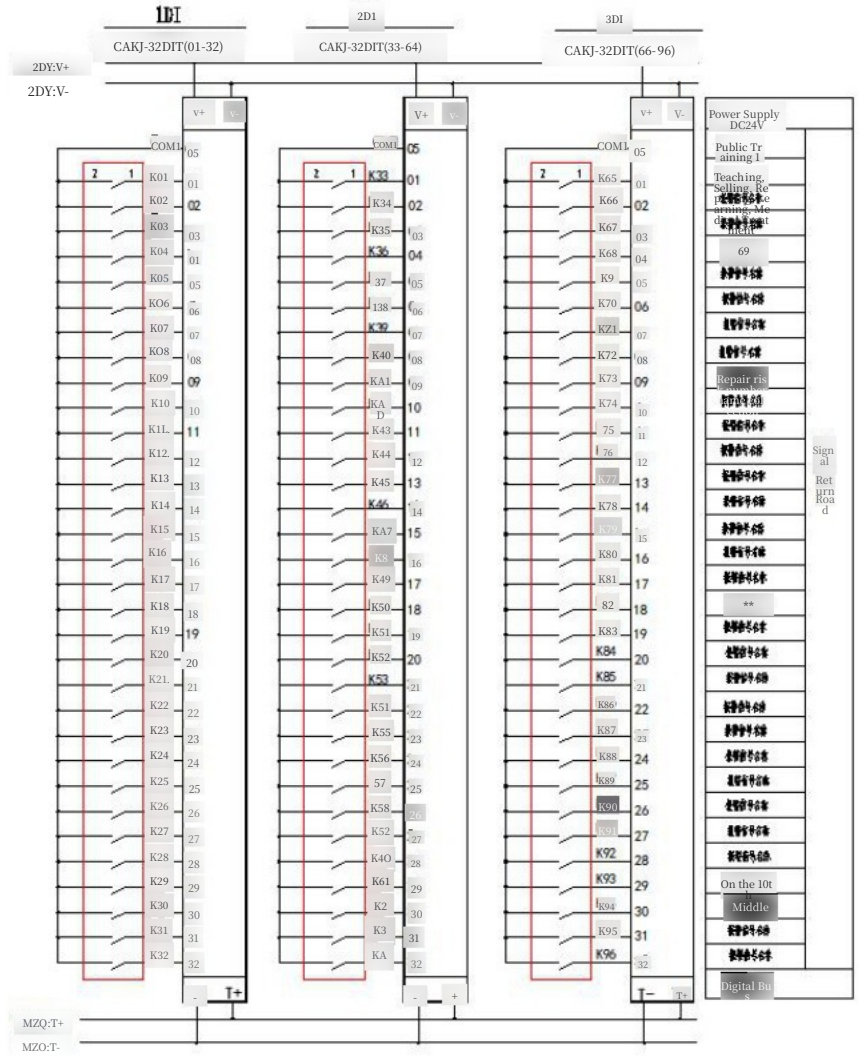
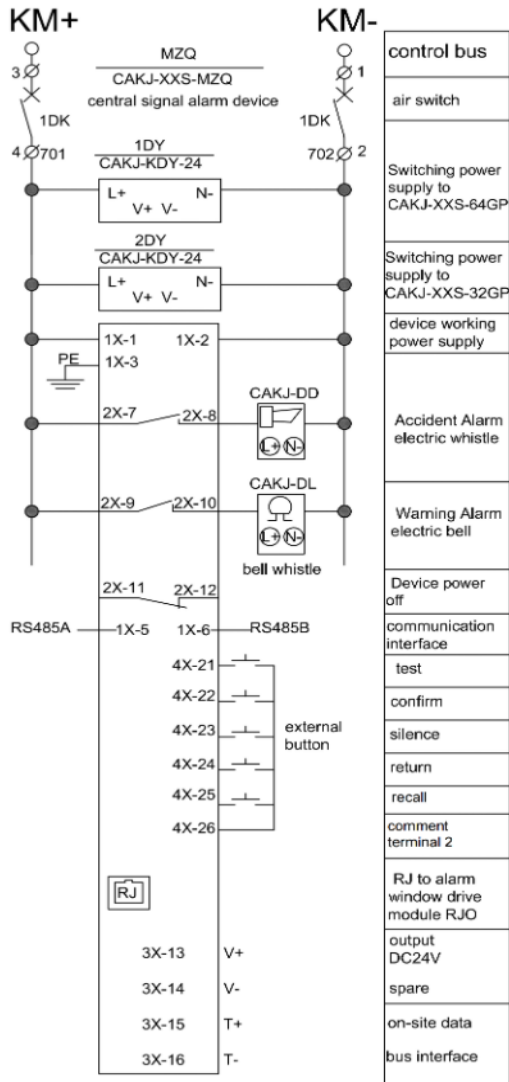
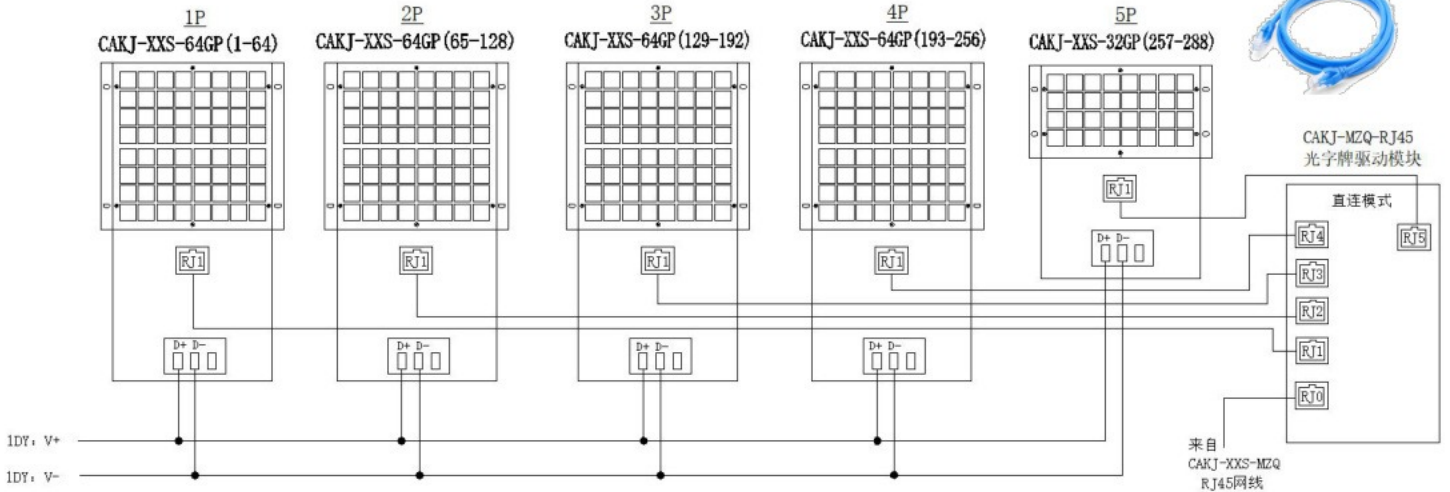



# Electronic bell and whistle (optional)

## I. Overview

CAKJ-DL, DD electronic bell and whistle, is a low-power, non-interference, and high-volume electronic alarm device designed for central signal alarm in the power system. Using a microcontroller to simulate the sound spectrum of an electromagnetic bell and whistle, the similarity between its sound and that of an electromagnetic bell and whistle reaches 98%.

### 2、 Model specifications

CAKJ-DL Electronic Bell

CAKJ-DD Electronic whistle

### 3、 Technical parameters

Working power supply: AC, DC80-265V, wide voltage

AC/DC universal, DC24V specified when ordering

Power consumption: not more than 3VA

Sound volume: 120DB

Electric ringtone: beeping ringtone, uninterrupted sound

Electric flute sound: beep, uninterrupted sound

Working mode: Power on sounds, power off sounds silent

Dielectric performance

Isolation voltage: Input terminal to ground 3000V, 1 minute

Insulation resistance: > 100M

Anti interference capability: The product can withstand the electrical fast transient pulse group immunity test with a test level of 4 specified in Chapter 5 of GB/T 17626.4-2008 Applicable environment: Temperature -25~55 , humidity not exceeding 90% RH

Mean time between failures: not less than 50000h

### 4、 External dimensions and wiring

External dimensions: 80x110x100mm Installation method: 35mm guide rail installation

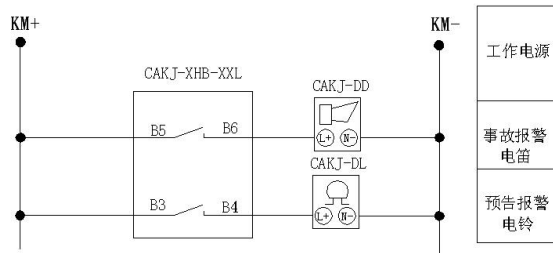
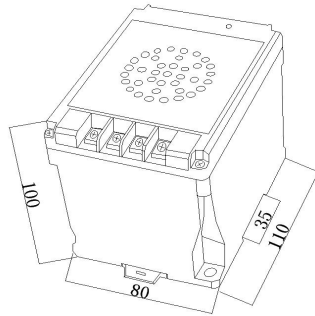

## Switcing Power Supply CAKJ-KDY-24

### ◆Overview

CAKJ-KDY-24 switch power supply is a switch mode power supply designed for the signal alarm system indicator light drive, or for the system that needs to convert the voltage of 220V, 110V, etc. into DC24V output.

### ◆Technical Parameters

Input Voltage: AC, DC220V (range 80-265V)

Output Voltage: DC24V

Stabilized Output Power: 24W (24V, 1A) (Suitable for driving below 128 light nameplates)

Applicable Environment: Temperature -25~55°C, Relative humidity not more than 90%

Mean Time Between Failures: Not less than 50000h

### ◆Dimensions and wiring

Dimensions: 80x110x100mm

Rail installation: 35mm Standard Rail

Fixed installation: 68x98-φ5

